

Rako RAK-4R Instruction Manual

Before Attempting To Program A System Refer To One Of The Following Documents :

RAK4 Wireless System Setup Guide (Systems Controlled By An RxLink)

Wired System Programming Guide (Systems Controlled By A RAKLink)

These Guides Are Saved In PDF Format On The CD Distributed With A RAKO Programming Device (RAUSB/RAHSmart/Bridge)

Overview

The Rako RAK-4R is a four channel controller which can be used to operate most types of Curtain, Blinds and Screen motors.

The RAK4-R has a single L-N-Earth 230v ac input. Each of the four outputs comprise two uncommitted volt-free relays. The relays can be wired or switched to suit the specific motor connected to them. The RAK4-R provides auxiliary Live outputs that can be used to drive ac motors.

The Rako RAK4-R is designed for use as a single 4 channel controller or to be stacked together to other RAK-4's to give more outputs.

RAK4-R can be stacked with other members of the RAK4 family, a single stack may contain a mixture of RAK-4T, RAK-4R, RAK-4L, RAK-4F etc.

Whether forming a single 4 channel rack or multiples each stack requires to be connected to an Rx-Link wireless receiver or RAK-Link wired unit. A single Rx-Link can support up to 4 RAK-4 units. A RAK-Link can support up to 8 RAK-4 units.

Each RAK-4R has an on-board fuse rated at 5A.

Before commencing installation of a Rako module first read this instruction manual carefully.

Rako Controls Ltd accepts no responsibility for any damage or injury caused by incorrect installation of a Rako product.

Installation should only be carried out by a qualified electrician.

Always install RAK-4 units in a well ventilated room, with a minimum clearance of 50mm on the sides in the correct orientation i.e. vents top and bottom.

Warning: Each RAK-4 unit must be earthed.

Installation

Step 1 - Secure Case to wall or secure mounting position. The RAK-4 system relies on being vertically mounted to allow the ventilation system to work properly.

Step 2 - If multiple RAK-4s are to be joined to form a larger 'stack' mount and join the other cases to join the original case using the connecting grommets (see Fig.1) cutting away enough plastic to allow cable access.

Step 3 - Bring a separate 10A MCB protected supply to each RAK-4 case. Connect the Earth and Neutral supply to the appropriate connector block and leave the Live ready to connect to the circuit board. Bring a feed from both the Earth and Neutral bars ready to connect to the circuit board (see Fig.1) Also feed the load Lives and prepare ready for connection to the circuit board and connect the load Neutral and Earths to the appropriate connector block.

Step 4 - Secure the circuit boards into position using the two fixing screws supplied and connect the Supply (LN&E) and the feeds to the loads.

Step 5 - On multiple assemblies of RAK-4s link the circuit boards using the interconnecting leads supplied, plugging them into the IN/OUT RJ45 sockets, ensuring that the cable guides are used to avoid the data cable from touching the heat sinks. The system interface (RxLink for wireless, or RAKLink for wired networks) should then plug into one of the remaining IN/OUT sockets.

Step 6 - Fit Lid

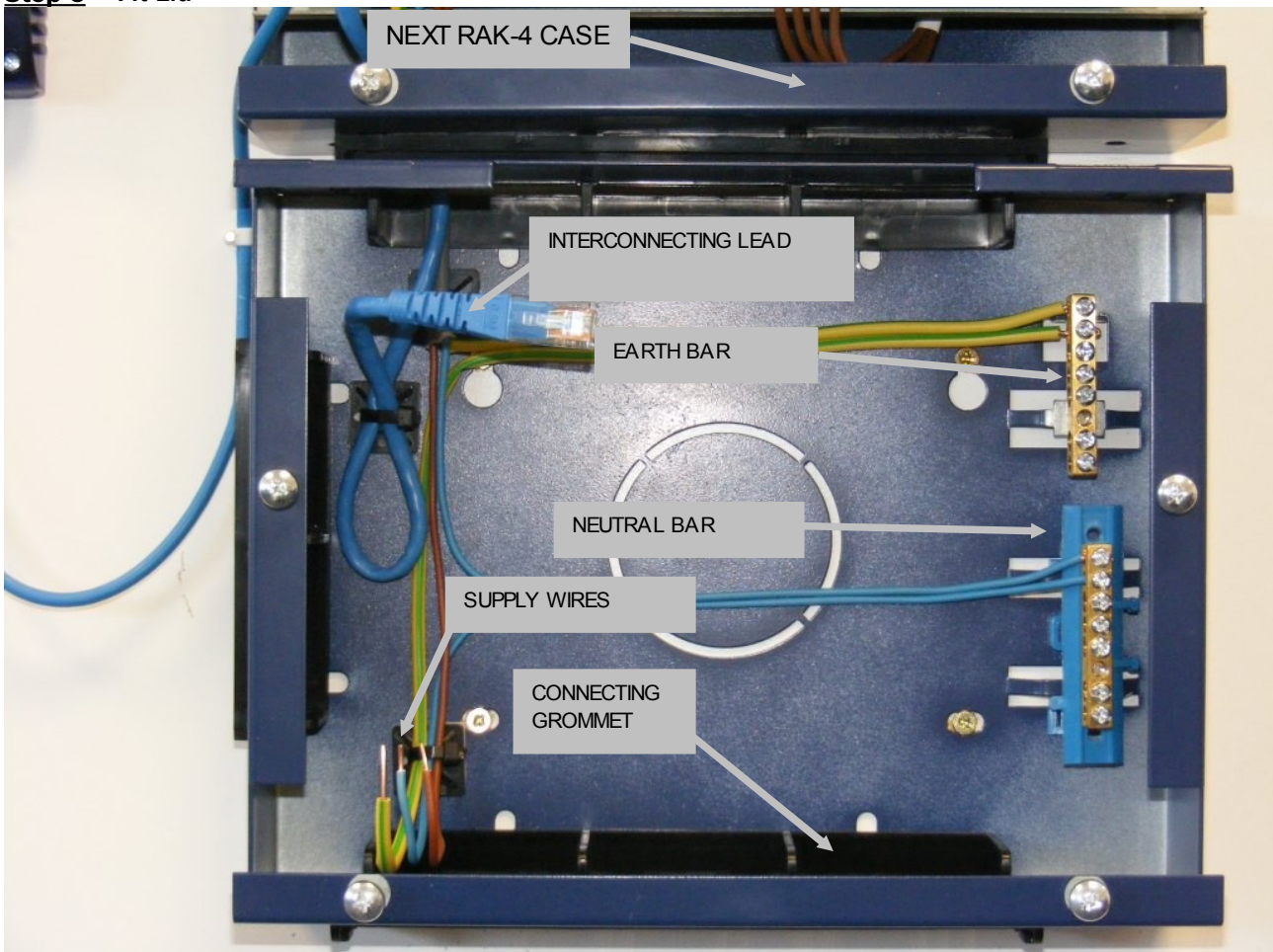

FIGURE. 1

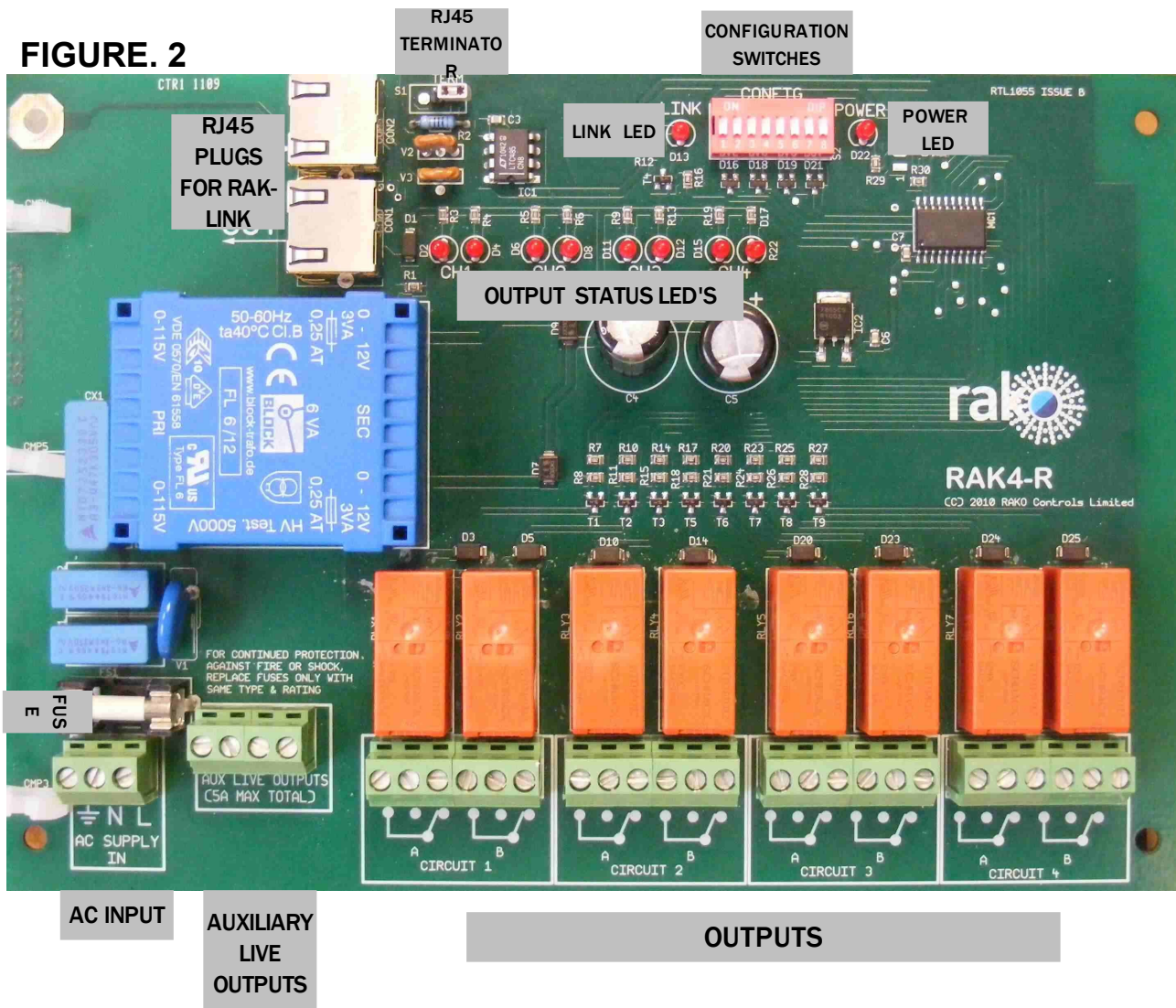

Figure 2 shows RAK-4R with relevant features labelled:

- AC Input:** Earth – Connect to Earth Bus bar in back of case
Neutral – Connect to Neutral Bus bar in back of case
Live – connect to 230v supply
- RJ45 Connectors:** Connect first RAK-4 to Rx-Link (or Rak-Link) using RJ45 cables supplied. Interconnect further RAK4's as required.
- RJ45 Terminator:** Fit a terminator jumper to the last RAK-4 to be connected – (the one furthest from the Rx-Link/Rak-Link). This jumper is only required if the RAK-4's are located more than 10 metres from the Rx-Link/Rak-Link.
- Configuration Switches:** Switches 1,2,3 set the Box Address for each RAK4 in a stack. In a stack each RAK-4 must have a different Box Address. When the system is programmed these Addresses are used in the Rasoft software to identify correct circuits.
- Link LED:** This LED will flash on when the RAK-4 stack receives data from the Rx-Link.
- Power LED:** This LED indicates that 230v ac is connected to the RAK-4

Outputs: There are four outputs: Circuit 1, Circuit 2, Circuit 3, Circuit 4.
Each output has 2 relays: A, B

OUTPUT STATUS

LED's Each Output relay has a status LED. The LED is lit when the relay is ON.

AUXILIARY LIVE

OUTPUTS: These outputs are used when the RAK-4R is connected to 230v ac motors. The Auxiliary Live outputs provide a convenient source of Live 230v which can be connected to the Relay outputs as required. (Neutral connections to motors can be made to the Bus-Bar in the back of the RAK-4 case).

Appendix - Wiring Example for Somfy ac motor

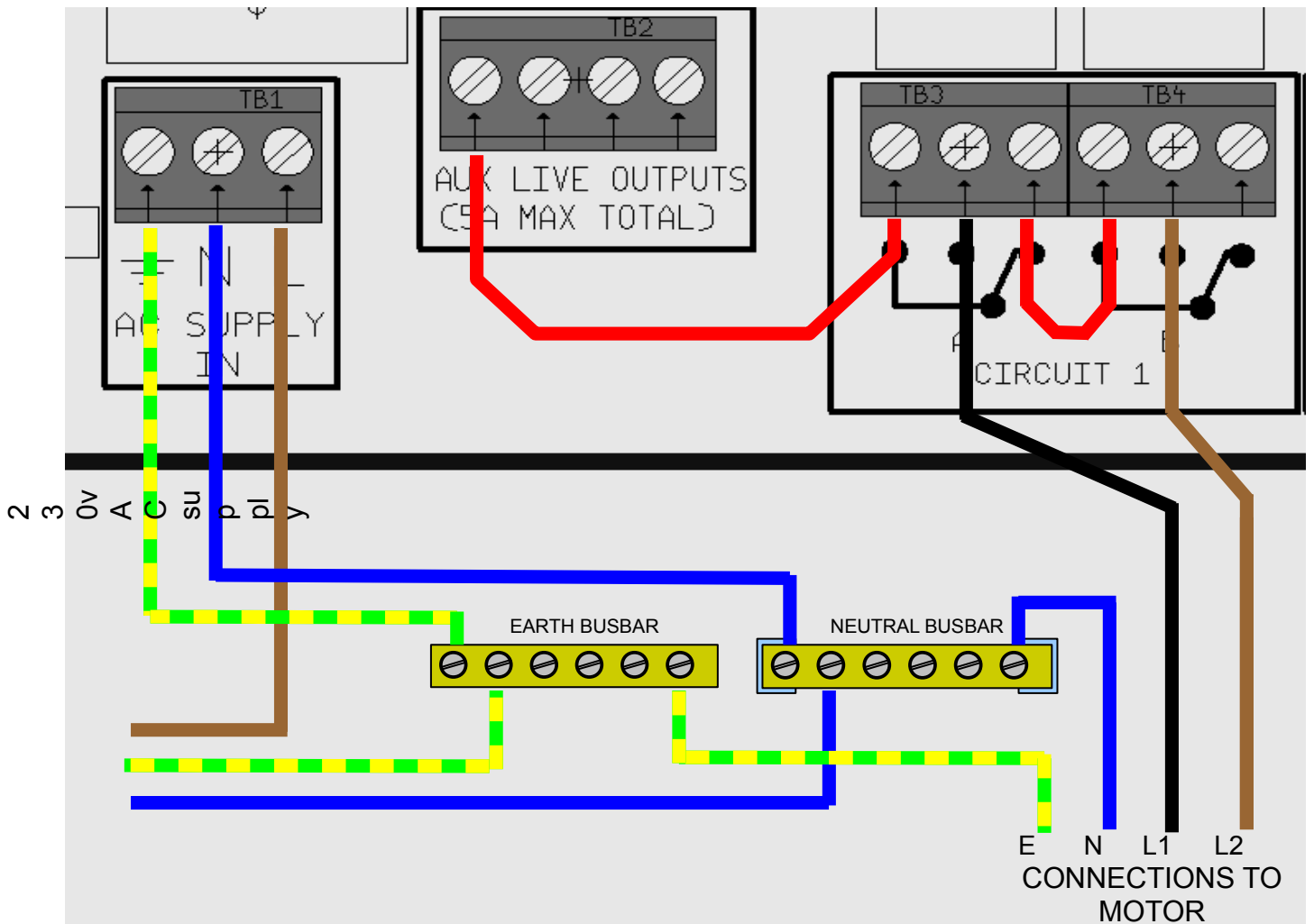

Specifications

Dimensions	253 x 192 x 102mm (w x h x d)
Supply	200-230VAC +/- 10% 50-60Hz 10A Type C MCB protected supply per RAK-4
Output	4 x Dual uncommitted changeover relay
Protection	5A 20mm fuse
Terminal sizes	4mm²
Standards	EMC-EN 5001-1:1992 Immunity-EN 50082-1:1997 Data
Communication	Rakom coded FM radio or Rako Wired system
Memory	Flash memory (non volatile)
In the Box	Housing x 1 Circuit board and mounting plate x 1 Lid & retaining screws x 1 Interconnecting lead x 1

For more information contact Rako Controls Ltd 01634 226666 www.rakocontrols.com